

TECHNI-FLO RV

SLOPED ROOF MEETS HIGH WALL, SHINGLED VERSION

INSTALLATION INSTRUCTIONS

U.S. PATENT # 7,823,343

DETAIL A

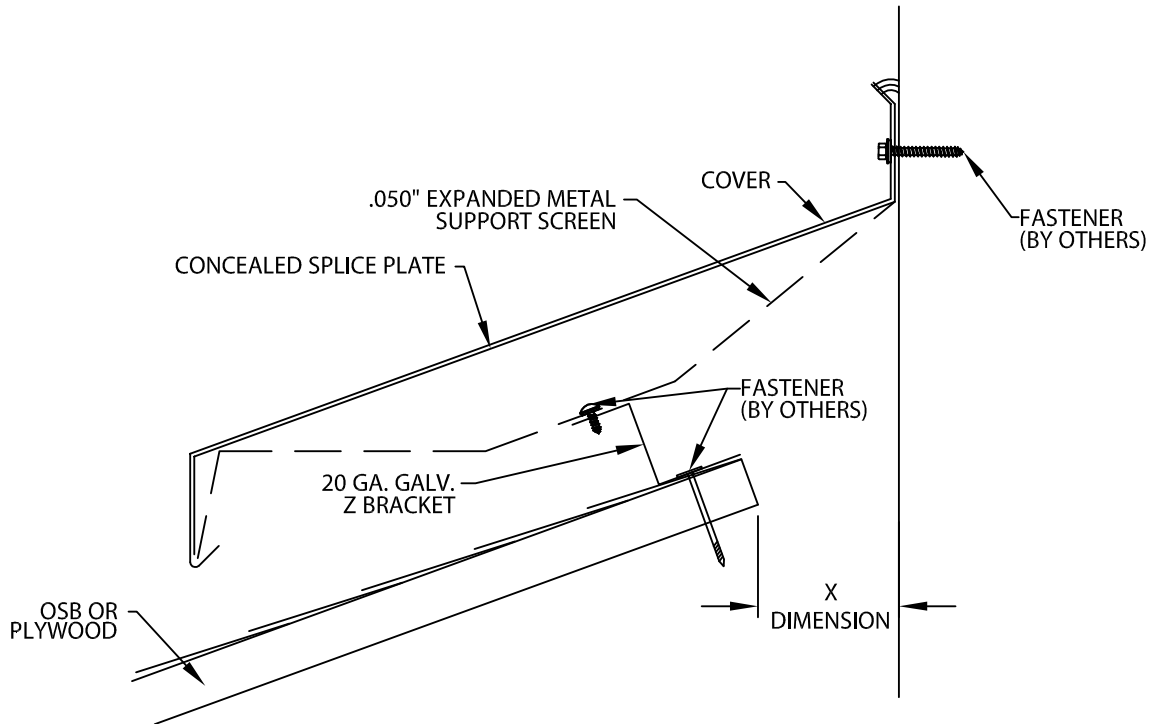

ATLAS ROOFING PROCESS
ENGINEER PLEASE
SPECIFY

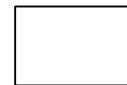

X DIMENSION

CAUTION! INSTALLERS SHALL WEAR PROTECTIVE EYE WEAR TO PREVENT INJURY. DO NOT OVERDRIVE FASTENERS, AS STRIPPING CAN OCCUR AT HIGH DRIVER TORQUE.
RECOMMENDED DRIVING TOOL: 600 - 800 rpm
ELECTRIC DRILL EQUIPPED WITH DEPTH-SENSING NOSE-PIECE TO PREVENT DRIVING AND STRIPOUT. DO NOT USE IMPACT TYPE TOOL.

IMPORTANT! BE SURE TO REMOVE PROTECTIVE PLASTIC FILM PRIOR TO INSTALLING EACH COVER SECTION.

NOTE: ALL FASTENERS MUST MEET MINIMUM 240 LB. PULL-OUT FOR SUBSTRATE.



Phone: 855-542-0918
Fax: 800-770-3934
roof.atlasroofing.com

DATE: 06/01/11	SHT.# <u>1</u> OF <u>3</u>	
DRN BY: JJC		
CKD BY: SAK	DWG# 38124-10918	C

TECHNI-FLO RV

SLOPED ROOF MEETS HIGH WALL, SHINGLED VERSION

INSTALLATION INSTRUCTIONS

U.S. PATENT # 7,823,343

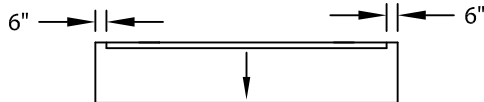

1. PREPARE RIDGE

CUT OPENING AT RIDGE "X" DIMENSION. (SEE DETAIL "A".)

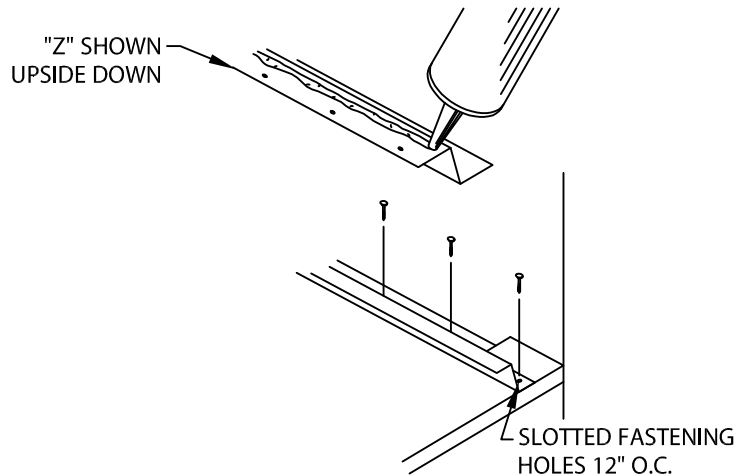

2. MOUNTING BRACKETS

TO PREVENT MOISTURE ENTRY UNDER THE "Z", APPLY A GENEROUS BEAD OF NON-CURING SEALANT TO BOTTOM OF FLANGE. FASTEN BRACKETS AT ROOF AT 6" (152 mm) O.C. WITH APPROPRIATE FASTENERS USING PRE-PUNCHED SLOTTED HOLES. LAP "Z'S" 1".

NOTE: FOAM/SEALANT SHOULD BE PLACED BETWEEN THE "Z" AND HIGH WALL OVER THE OSB ON THE LAST 6" AT BOTH ENDS (SEE STEP 1)

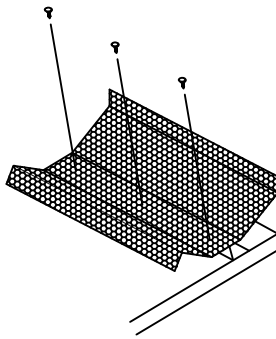

3. EXPANDED METAL SUPPORT SCREEN

PLACE SUPPORT SCREEN CENTERED OVER "Z" BRACKET. FASTEN AT 12" (305 mm) O.C. TO "Z" BRACKET. LAP SUPPORT SCREENS 1".

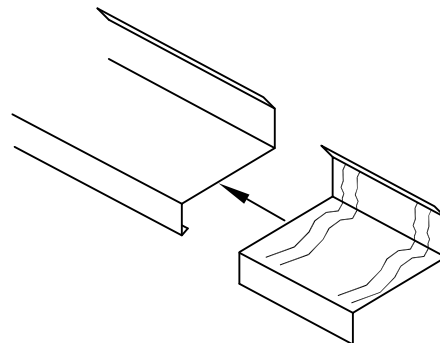

4. SPLICE PLATES

8" CONCEALED SPLICE PLATE SUPPLIED AT EACH COVER JOINT. APPLY SEALANT TO TOP OF SPLICE PLATES AS SHOWN. INSTALL THE SPLICE PLATE INTO ONE END OF 12'-0" COVER SO THAT HALF THE SPLICE PLATE IS EXPOSED.



Phone: 855-542-0918
Fax: 800-770-3934
roof.atlasroofing.com

DATE: 06/01/11

SHT.# 2 OF 3

DRN BY: JJC

CKD BY: SAK

DWG# 38124-10918

C

TECHNI-FLO RV

SLOPED ROOF MEETS HIGH WALL, SHINGLED VERSION

INSTALLATION INSTRUCTIONS

U.S. PATENT # 7,823,343

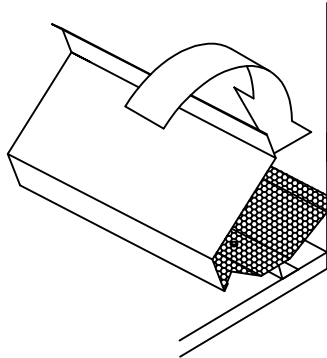

5. COVER

SNAP COVER INTO PLACE STARTING AT SLOPED END. HOOK THE EXPANDED METAL SUPPORT SCREEN INTO THE COVER LIP. ROTATE COVER DOWNWARD.

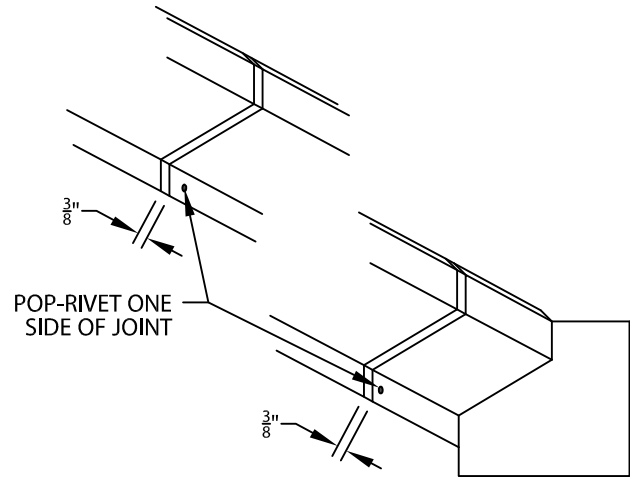

6. POP-RIVET

POP-RIVET SPLICE TO ONE SIDE JOINT TO PREVENT JOINT MIGRATION. CONTINUE INSTALLING COVER WITH A $\frac{3}{8}$ " (10 mm) SPACE AT SPLICE PLATES TO ALLOW FOR THERMAL EXPANSION FIELD CUT WHERE REQUIRED USING A FINE TOOTH HACKSAW. INSTALL THE END CAP (STYLE A SHOWN) IN THE SAME FASHION. NOTE: REMOVE PROTECTIVE FILM IMMEDIATELY.

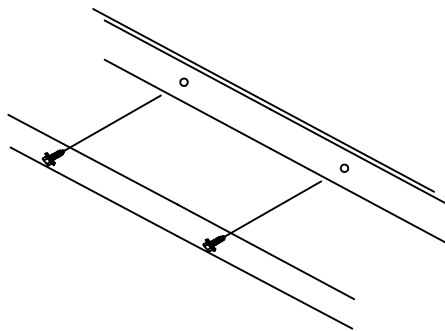

7. FASTEN

FASTEN TO WALL 12" (305 mm) O.C. WITH APPROPRIATE FASTENERS USING PRE-PUNCHED SLOTTED HOLES. NOTE: ONE FASTENER REQUIRED FOR EACH END CAP.

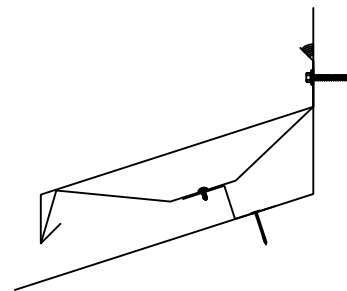

8. SEALANT

TO PREVENT MOISTURE ENTRY BEHIND THE "CAULK LIP", APPLY A GENEROUS BEAD OF NON-CURING SEALANT BETWEEN THE "CAULK LIP" AND THE HIGH WALL



Phone: 855-542-0918
Fax: 800-770-3934
roof.atlasroofing.com

DATE: 06/01/11
DRN BY: JJC
CKD BY: SAK

SHT.# 3 OF 3

DWG# 38124-10918

C