

TECHNI-FLO RV

SLOPE TO SLOPE, STANDING SEAM VERSION

INSTALLATION INSTRUCTIONS

U.S. PATENT # 8,075,376 B1

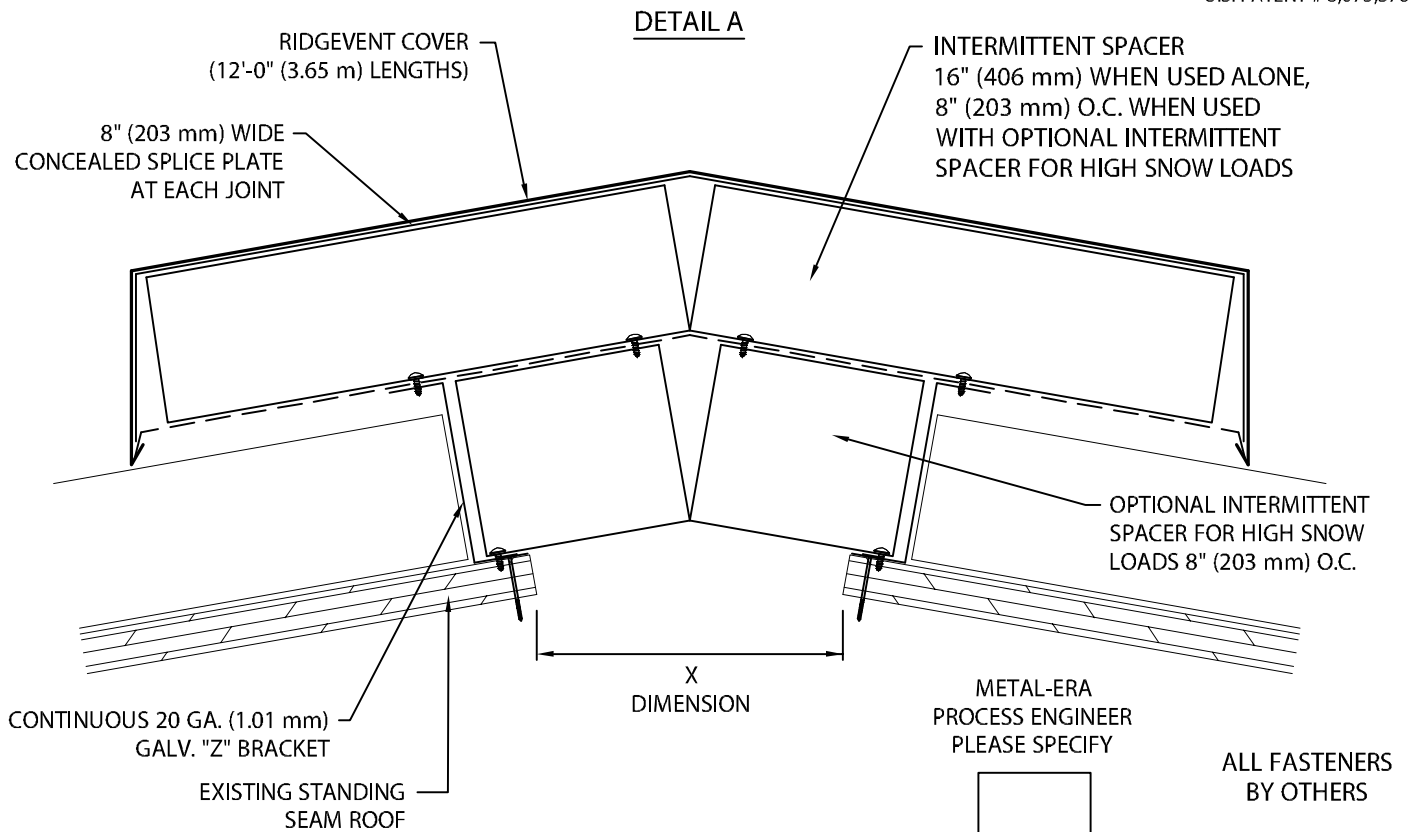

CAUTION! INSTALLERS SHALL WEAR PROTECTIVE EYE WEAR TO PREVENT INJURY. DO NOT OVERDRIVE FASTENERS, AS STRIPPING CAN OCCUR AT HIGH DRIVER TORQUE. RECOMMENDED DRIVING TOOL: 600 - 800 rpm ELECTRIC DRILL EQUIPPED WITH DEPTH-SENSING NOSE-PIECE TO PREVENT DRIVING AND STRIPOUT. DO NOT USE IMPACT TYPE TOOL.

IMPORTANT! BE SURE TO REMOVE PROTECTIVE PLASTIC FILM PRIOR TO INSTALLING EACH COVER SECTION.

NOTE: ALL FASTENERS MUST MEET MINIMUM 240 LB. PULL-OUT FOR SUBSTRATE.

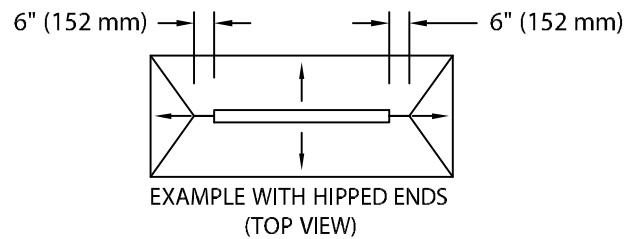
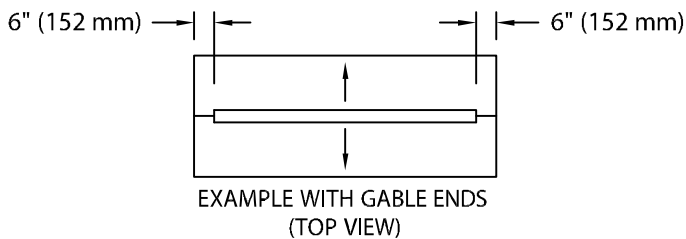

1. PREPARE RIDGE

CUT OPENING AT RIDGE "X" DIMENSION. END THE OPENING 6" (152 mm) BEFORE GABLE OR HIPPED END.



Phone: 855-542-0918
 Fax: 800-770-3934
 roof.atlasroofing.com

DATE: 02/06/12	SHT.# 1 OF 5
DRN BY: JJC	DWG# 38124-14982
CKD BY: SAK	

TECHNI-FLO RV

SLOPE TO SLOPE, STANDING SEAM VERSION

INSTALLATION INSTRUCTIONS

U.S. PATENT # 8,075,376 B1

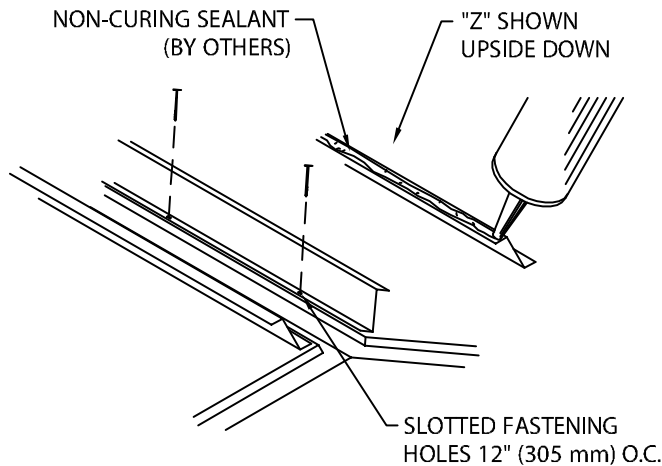

2. MOUNTING BRACKETS

TO PREVENT MOISTURE ENTRY UNDER THE "Z", APPLY A GENEROUS BEAD OF NON-CURING SEALANT (BY OTHERS) TO BOTTOM OF FLANGE. FASTEN BRACKETS AT ROOF AT 12" (305 mm) O.C. WITH APPROPRIATE FASTENERS USING PRE-PUNCHED SLOTTED HOLES. LAP "Z'S" 1" (25 mm).

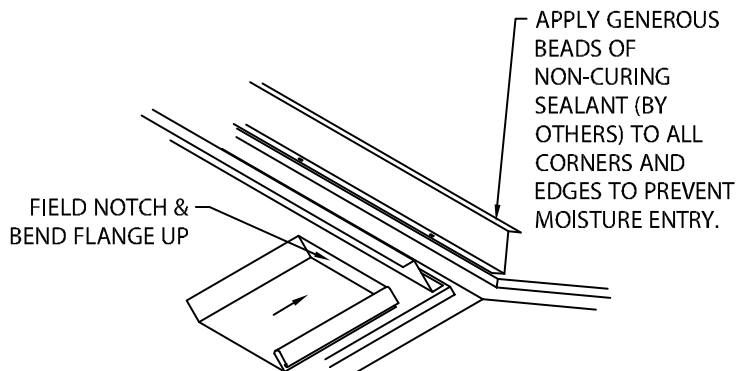

3. STANDING SEAM ROOFING

FOLLOW MANUFACTURER'S RECOMMENDATIONS FOR TERMINATING STANDING SEAM AT RIDGE VENT CHANNEL. SEE ABOVE FOR TYPICAL DETAIL.

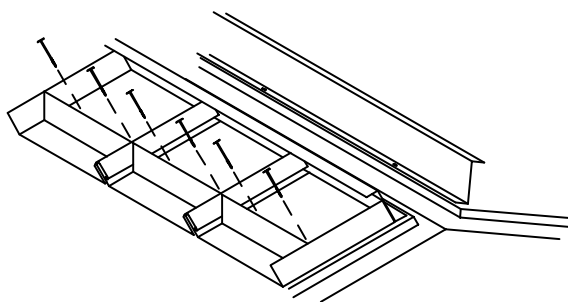

4. STANDING SEAM DEFLECTOR

PROVIDED FOR 4/12 PITCH OR LESS IN 12'-0" (3.65 m) LENGTHS TO BE CUT IN FIELD TO FIT BETWEEN THE STANDING SEAMS. CUT DEFLECTORS $\frac{3}{8}$ " (10 mm) SHORTER THAN THE MEASURED DISTANCE BETWEEN STANDING SEAMS. CENTER BETWEEN SEAMS ALLOWING $\frac{3}{16}$ " (5 mm) GAP AT BOTH ENDS FOR RESIDUAL WATER DRAINAGE. FASTEN WITH #10 x $\frac{3}{4}$ " (19 mm) TEK SCREWS WITH BOND SEAL WASHERS AS SHOWN.

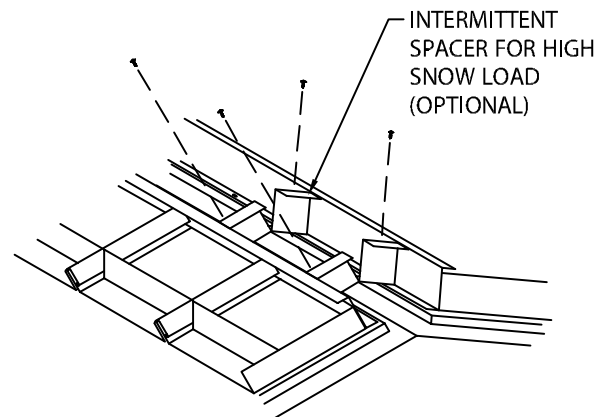

5. INTERMITTENT SPACER (OPTIONAL SNOW BRACE)

TO PREVENT COLLAPSE IN HIGH SNOW LOAD AREAS, FASTEN OPTIONAL INTERMITTENT SPACER 8" (203 mm) O.C. AS SHOWN WITH APPROPRIATE FASTENERS.



Phone: 855-542-0918
Fax: 800-770-3934
roof.atlasroofing.com

DATE: 02/06/12

SHT.# 2 OF 5

DRN BY: JJC

CKD BY: SAK

DWG#38124-14982

A

TECHNI-FLO RV

SLOPE TO SLOPE, STANDING SEAM VERSION

INSTALLATION INSTRUCTIONS

U.S. PATENT # 8,075,376 B1

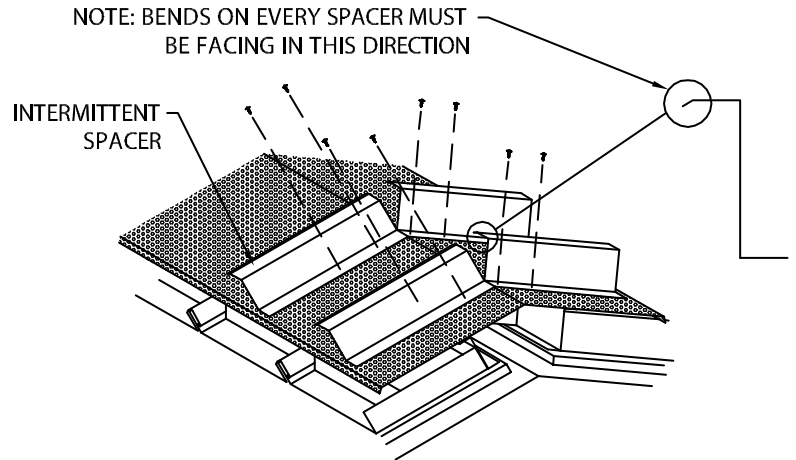
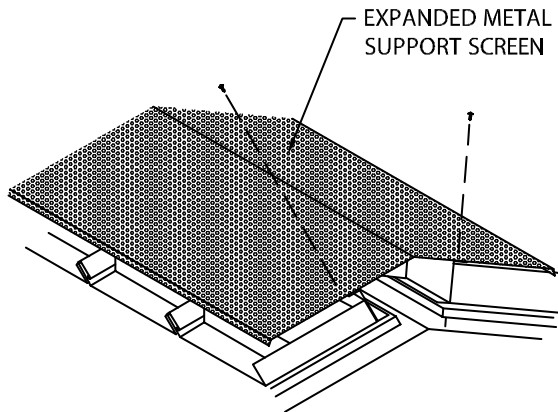

6. EXPANDED METAL SUPPORT SCREEN

PLACE ONE SCREEN CENTERED OVER BRACKETS. TEMPORARILY FASTEN TO "Z" BRACKETS AT BOTH ENDS OF 12'-0" (3.65 m) SCREEN (FOUR FASTENERS TOTAL).

IN ORDER TO MINIMIZE THE LENGTH OF SCREEN AND SPACERS THAT THE COVER WILL SLIDE ONTO, START BY INSTALLING TWO LENGTHS OF SCREEN (LAP SCREENS 1" (25 mm)) WITH THE APPROPRIATE INTERMITTENT SPACERS (SPACER INSTALLATION, STEP 7) AFTER ENDCAP IS INSTALLED (STEP 9) SLIDE FIRST COVER INTO PLACE. FROM THERE INSTALL ONE SCREEN AND APPROPRIATE SPACERS AND IMMEDIATELY SLIDE ON ONE COVER.

7. INTERMITTENT SPACERS

STARTING AT THE END OF THE ROOF WHERE THE ENDCAPS WILL BE PLACED, FASTEN INTERMITTENT SPACERS (16" (406 mm) O.C. WHEN USED ALONE, 8" (203 mm) O.C. WHEN USED WITH OPTIONAL SNOW BRACE) AS SHOWN WITH APPROPRIATE FASTENERS. THE BENDS ON TOP OF THE SPACER MUST ALL BE FACING AWAY FROM THE END OF THE ROOF.

STYLE A

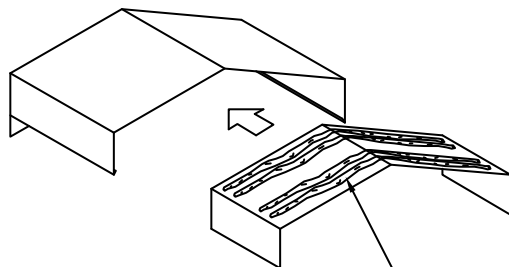

NON-CURING SEALANT (BY OTHERS)

STYLE B

(FLASH IN PER SHINGLE/STANDING SEAM MANUFACTURER'S RECOMMENDATIONS)

8. ENDCAP SPLICE PLATES

8" (203 mm) CONCEALED SPLICE PLATE SUPPLIED AT EACH END CAP AND COVER JOINT. APPLY NON-CURING SEALANT (BY OTHERS) TO TOP OF SPLICE PLATES AS SHOWN. INSTALL THE SPLICE PLATE INTO END OF END CAP SO THAT HALF THE SPLICE PLATE IS EXPOSED.



Phone: 855-542-0918
Fax: 800-770-3934
roof.atlasroofing.com

DATE: 02/06/12

SHT.# 3 OF 5

DRN BY: JJC

CKD BY: SAK

DWG# 38124-14982

A

TECHNI-FLO RV

SLOPE TO SLOPE, STANDING SEAM VERSION

INSTALLATION INSTRUCTIONS

U.S. PATENT # 8,075,376 B1

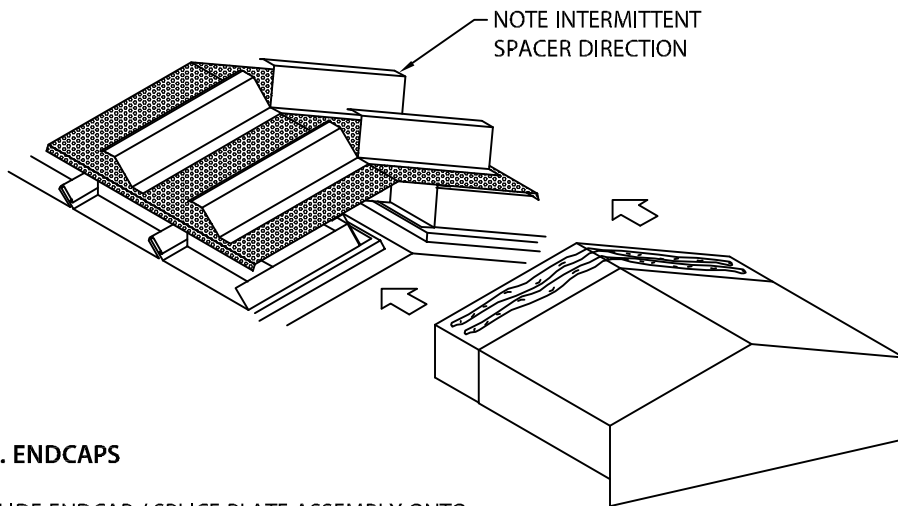

9. ENDCAPS

SLIDE ENDCAP / SPLICE PLATE ASSEMBLY ONTO EXPANDED METAL SUPPORT SCREEN. REMOVE PROTECTIVE FILM IMMEDIATELY.

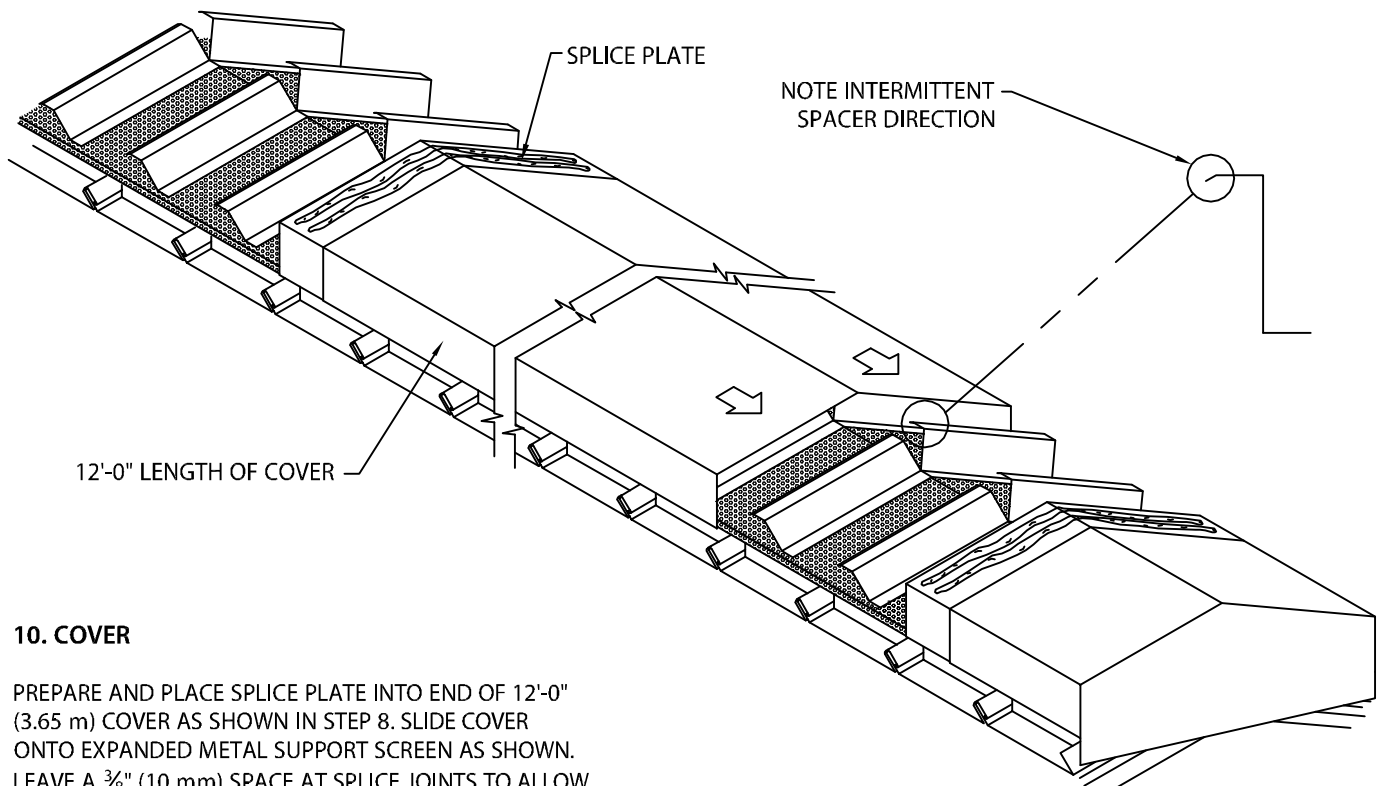

10. COVER

PREPARE AND PLACE SPLICE PLATE INTO END OF 12'-0" (3.65 m) COVER AS SHOWN IN STEP 8. SLIDE COVER ONTO EXPANDED METAL SUPPORT SCREEN AS SHOWN. LEAVE A $\frac{3}{8}$ " (10 mm) SPACE AT SPLICE JOINTS TO ALLOW FOR THERMAL EXPANSION. FIELD CUT WHERE REQUIRED USING A FINE TOOTH HACKSAW.



Phone: 855-542-0918
Fax: 800-770-3934
roof.atlasroofing.com

DATE: 02/06/12

SHT.# 4 OF 5

DRN BY: JJC

CKD BY: SAK

DWG# 38124-14982

A

TECHNI-FLO RV

SLOPE TO SLOPE, STANDING SEAM VERSION

INSTALLATION INSTRUCTIONS

U.S. PATENT # 8,075,376 B1

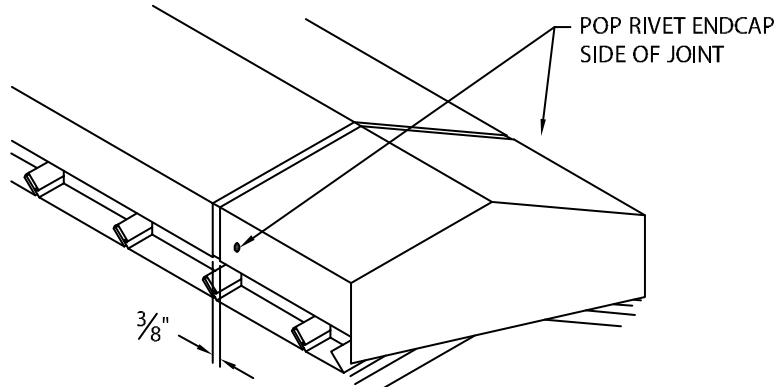

11. POP-RIVET

POP-RIVET SPLICE TO ENDCAP SIDE JOINT TO PREVENT JOINT MIGRATION. AFTER THIS STEP IS COMPLETE, START AGAIN AT STEP 10 AND REPEAT THESE STEPS TO COMPLETION. WHEN INSTALLING COVER LEAVE A $\frac{3}{8}$ " (10 mm) SPACE AT SPLICE JOINTS TO ALLOW FOR THERMAL EXPANSION. FIELD CUT WHERE REQUIRED USING A FINE TOOTH HACKSAW.

NOTE: REMOVE PROTECTIVE FILM IMMEDIATELY



Phone: 855-542-0918
Fax: 800-770-3934
roof.atlasroofing.com

DATE: 02/06/12

SHT.# 5 OF 5

DRN BY: JJC

CKD BY: SAK

DWG# 38124-14982

A